

# EVA1022 Technical Data

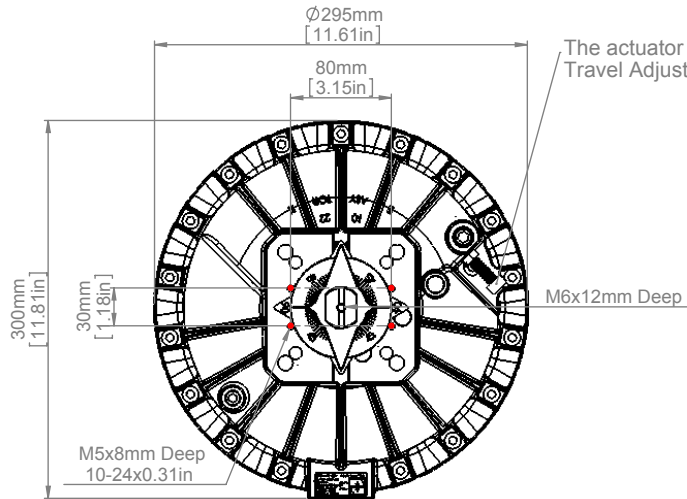

MOUNTING DIMENSIONS PER  
ISO 5211-2001(E)  
DIN 3337(OPTIONAL)  
NAMUR VDI/VE 3845



The actuator is factory adjusted to produce 90° rotation.  
Travel Adjustment +/- 5° per stopper bolt (2x per actuator)

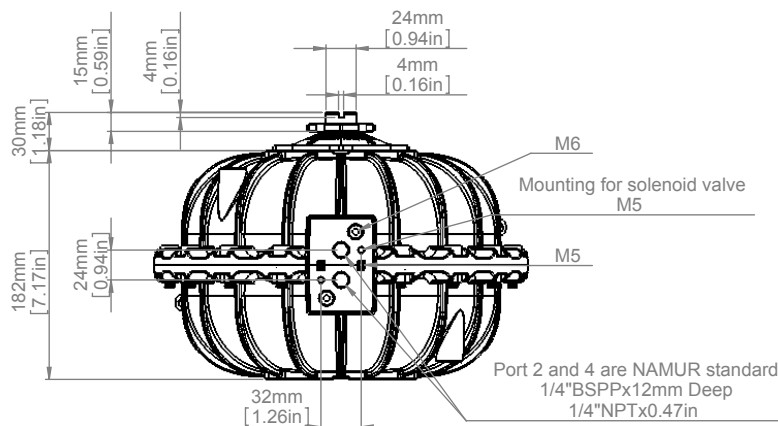
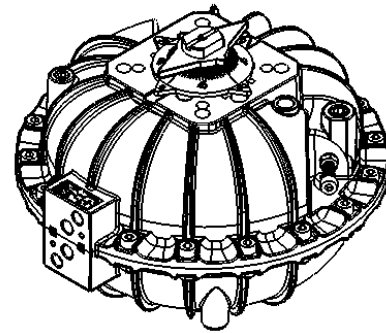

Semi Direct Mount-(With Optional Shaft)

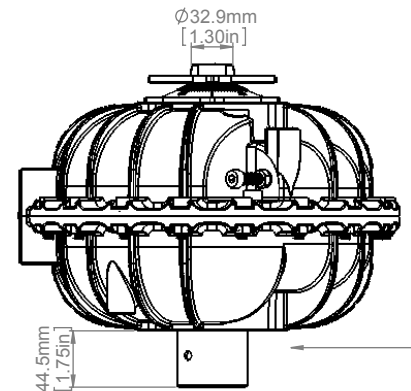

Model 1022 ISO F07/F10/F12 Pattern 0° Shift

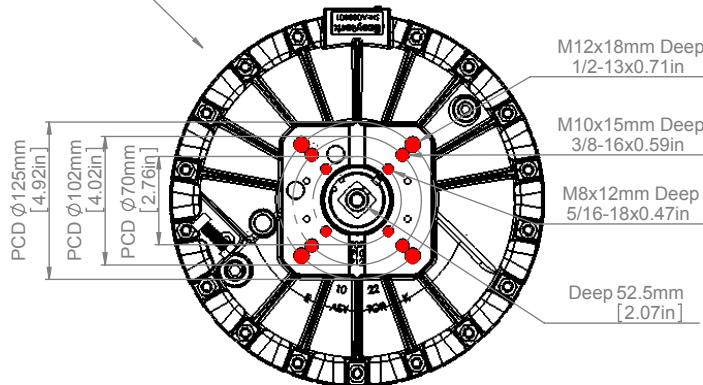

**Standard Insert**

All actuators are fitted with adaptable drive inserts in order to accommodate different valve stem profiles. custom DD, Bore & key, Sq shape available

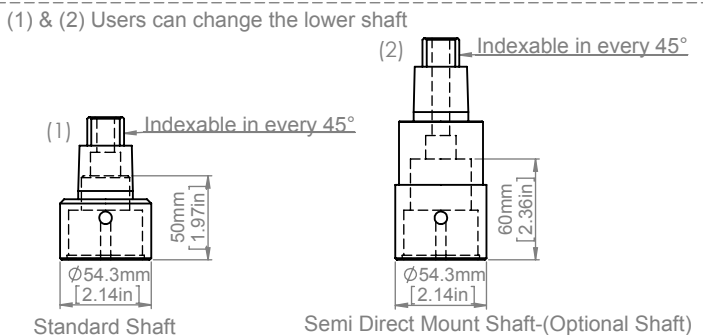

- Note:**
- Output torque:  
3051 In/Lb 343.8 Nm at 80 psi / 5.5 bar - Double Acting  
1983 In/Lb 223.4 Nm at 80 psi / 5.5bar - Fail Safe
  - Pressure rating 2-10 bar (30-150 psi)
  - Actuator shown in full CW position
  - Travel adjustment ±5° per stopper bolt
  - Ancillaries attachment size AA2
  - Weight 10 kgs (22.0 lbs)
  - Air consumption per stroke at 5.5 bar (80psi)  
7.8L (480 cu-in)
  - Standard Coating finish material: epoxy
  - Temp range: Silicone vane seal -40°C to -120°C or  
-40°F to 248°F



2505 Metro Blvd, Suite A/B, Maryland Heights, 63043 USA  
info@easytork.com www.easytork.com