

Fail-Safe Efficiencies @ 5.5 bar (80 psi)

- Drawings and figures reflect real life data.

Comparable Model: Size

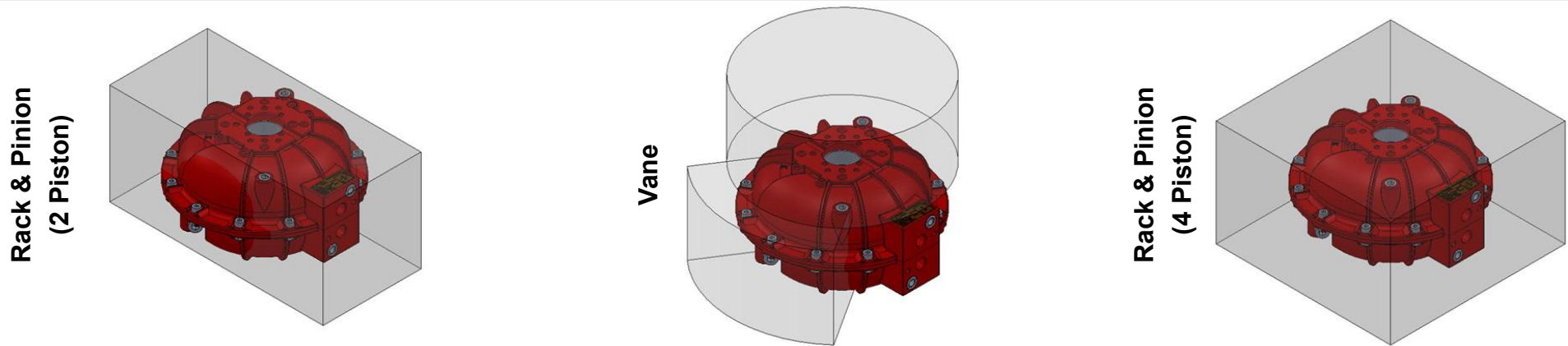

Comparable Model: Weight

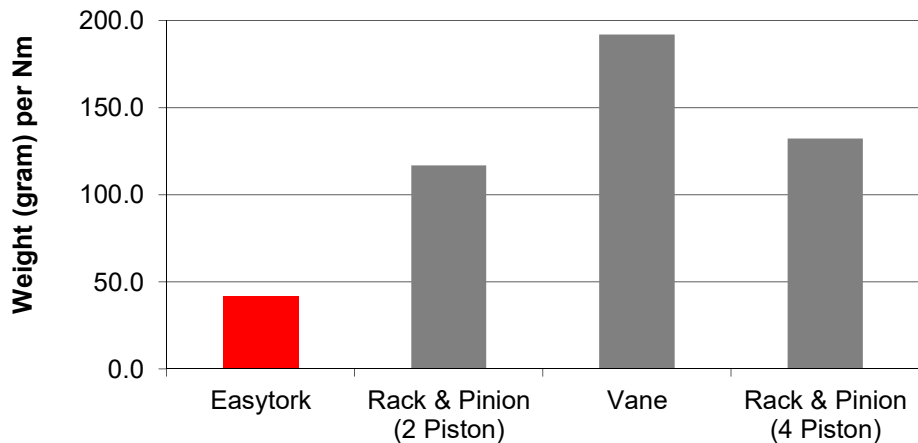

Comparable Model: Air Consumption

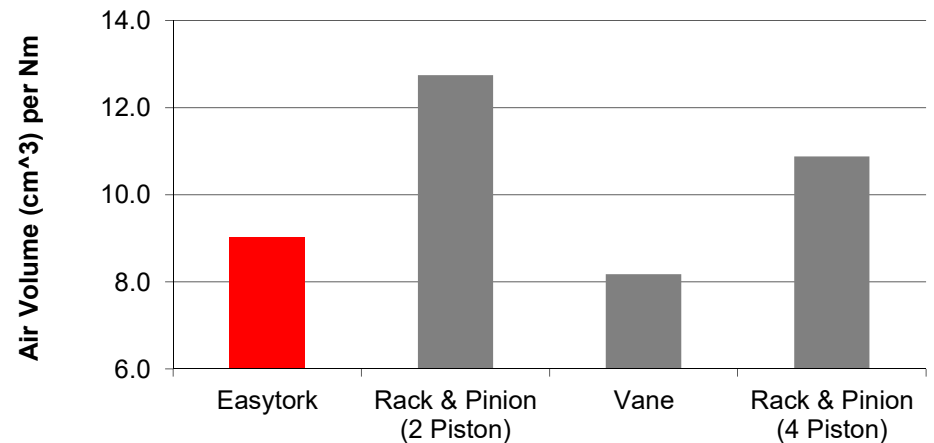

Note:

The EVA air reservoir is charged only once, and over the course of a fail-safe operation the air in the reservoir is never displaced to the atmosphere (only diverted to the vane chamber).

Double-Acting Efficiencies @ 5.5 bar (80 psi)

Drawings and figures reflect real life data.

Comparable Model: Size

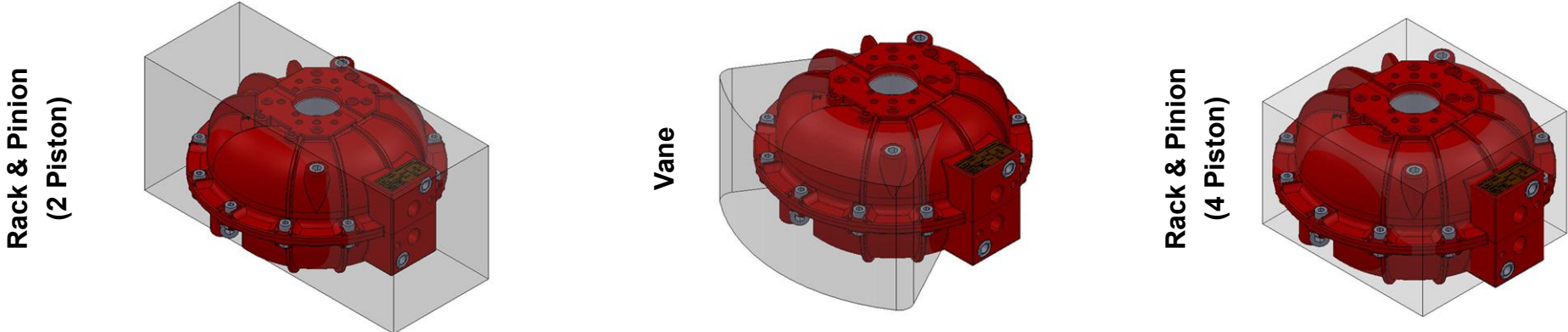

Comparable Model: Weight

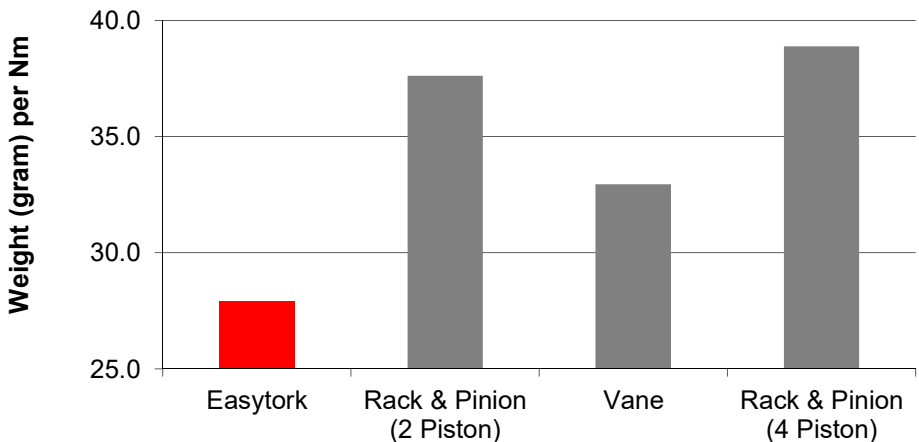

Comparable Model: Air Consumption

