

Specifications:

- 1. Output Torque**
 DA 2607 Nm @ 5.5 bar / 23141 in-lb @ 80 psi
 FS 1746.5 Nm @ 5.5 bar / 15503 in-lb @ 80 psi
- 2. Temperature Rating**
 -40°C to 120°C / -40°F to 248°F
- 3. Pressure Rating**
 Up to 10 bar (150 psi)
- 4. Weight**
 75.6 kg / 166.7 lb
- 5. Displaced Air Volume Per Stroke**
 9.6 L / 585.8 in³
- 6. Travel Adjustment**
 +/- 5° per stopper bolt for standard

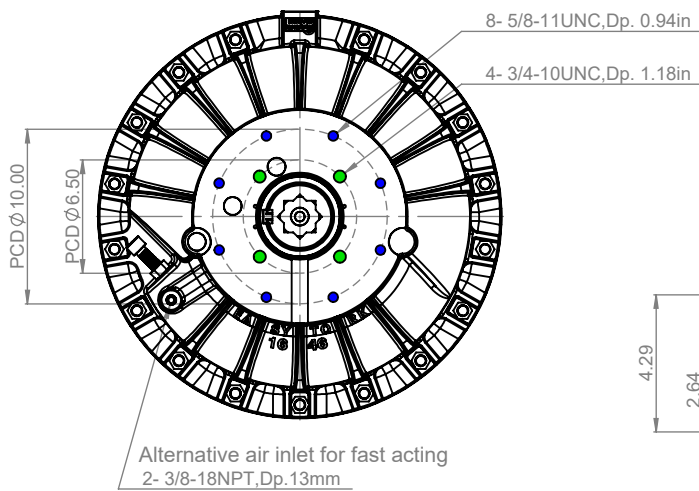
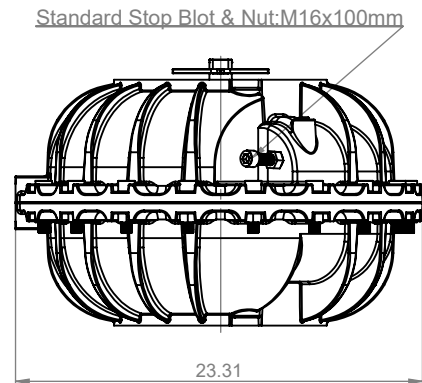
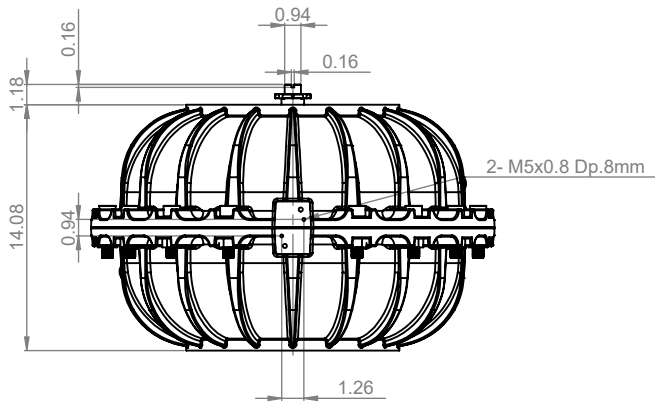
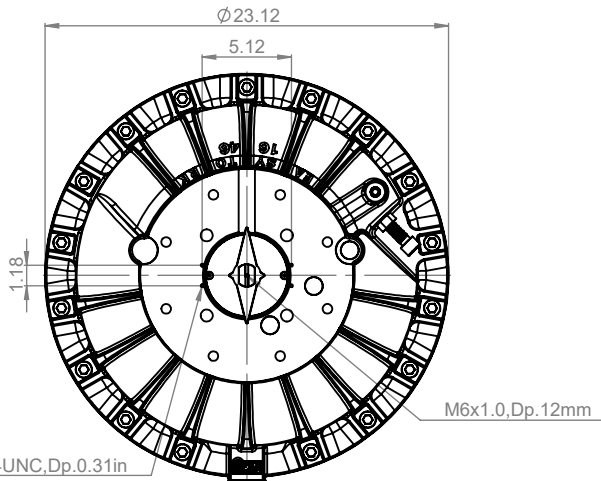

Actuator shown in full CW position
 Ancillaries attachment size AA3

Direct Mount Shaft in EVA
 (Available Space For Valve Stem)

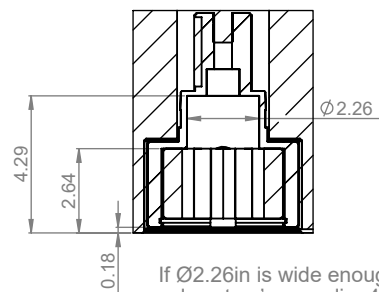

If $\phi 2.26$ in is wide enough for valve stem's max dia., 4.29in is max valve stem depth. If not, use 2.64in.

Insert 46X46mm square

